

# HOPPERTOP

Weigh Hopper Venting Filter

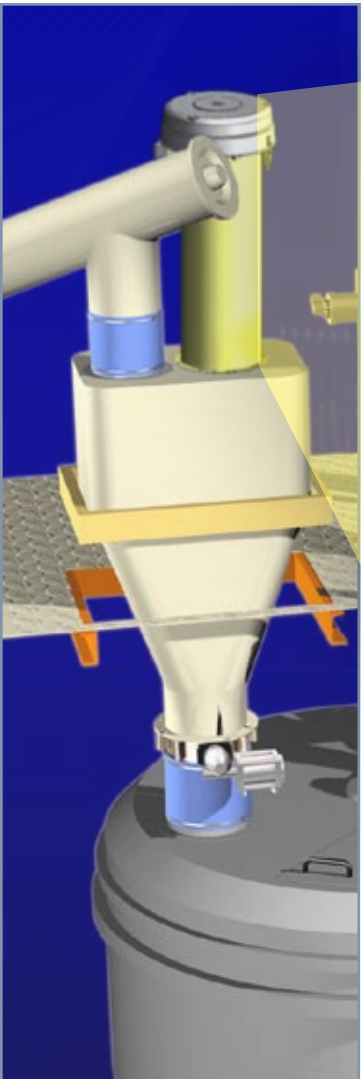

**SMALL FOOTPRINT**

**EASY TO ASSEMBLE**

**MAINTENANCE-FRIENDLY**

**PATENTED**

# HOPPERTOP

Weigh Hopper Venting

## THE TOP CHOICE FOR HOPPER VENTING IN CONCRETE PLANTS

HOPPERTOP is a COMPACT air filter specially developed for venting of mechanically loaded cement weigh hoppers in concrete plants.

Dust which is separated from the air flow by a single WAM® cartridge filter element drops back into the hopper after an integrated automatic reverse air jet cleaning system inside the weather protection cover has removed the dust particles from the filter elements.

### Features

- Compact dimensions
- Stainless steel design
- Hinged cover
- Approved cartridge quality
- Cartridge removal without tools
- High-performance filter cartridge

### Overall Dimensions

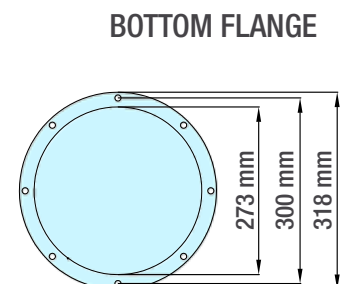
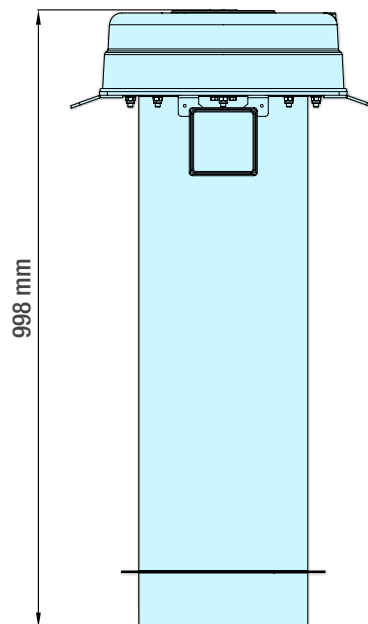
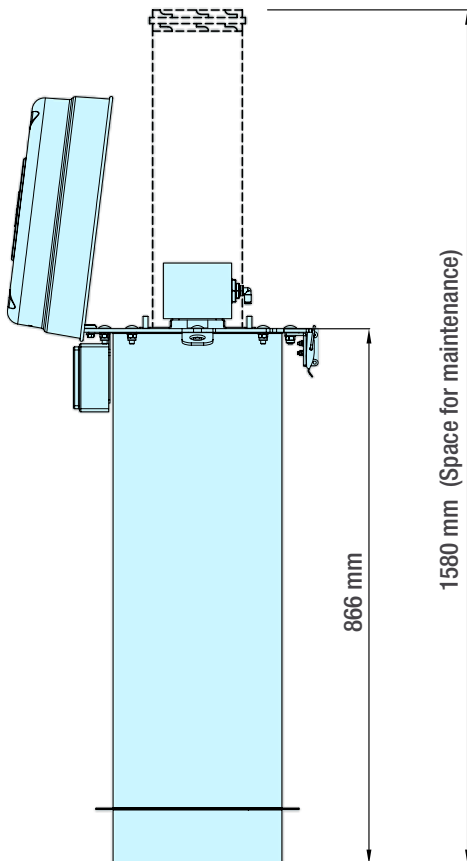

MODEL	TYPE	FILTER SURFACE (m <sup>2</sup> )
HTP10001V	VENTING	1
HTP10001R	TOP CONNECTION	1

## Benefits



Maintenance height:  
870 mm

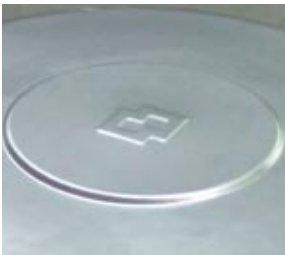

Long durability thanks  
to stainless steel  
construction



Easy maintenance  
thanks to hinged top  
cover and cartridge  
removal without tools



Small footprint and  
easy to handle



Durable thanks to  
wide pleat cartridge  
geometry

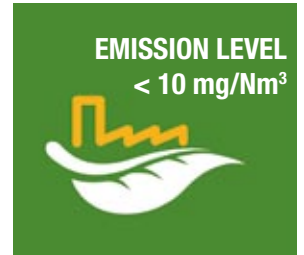

Compliance with  
Dust Emission laws  
due to high-efficiency  
filter media

## Accessories

### Cover for external pipe connection

- Required for dust emission sampling connection
- Robust powder-coated steel cover
- Easy to fit to existing venting versions

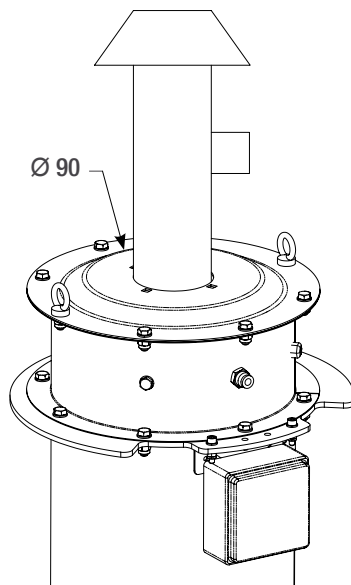

### Electronic Differential Pressure Meter



- Filter DP continuously measured and displayed on 3 digit display;
- Cleaning activation with pressure threshold;
- Alarm pressure can switch on external device;
- 4-20 mA exit to read DP value on plant PLC;
- Possible to install on existing filters.

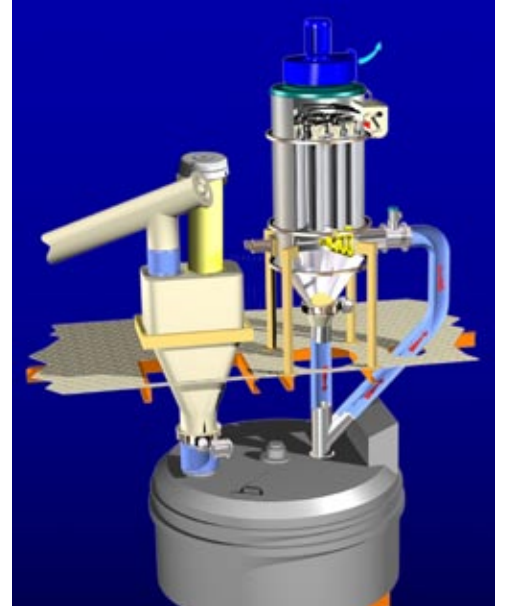

## Typical Application:

- Venting of mechanically filled weigh hoppers in concrete batching plants

For further information visit  
[www.wamgroup.com](http://www.wamgroup.com)

